



Owner's Manual

Original Instructions

Commercial Air Conditioners

Fan Coil Unit Wall Mounted Type

Models:

FP-34BXX/D-K

FP-51BXX/D-K

FP-68BXX/D-K

FP-85BXX/D-K

FP-34BXN/A-K

FP-51BXN/A-K

FP-51BWXN/A-K

FP-68BXN/A-K

FP-85BXN/A-K

FP-85BWXN/A-K

FP-34BXN/B-D

FP-51BXN/B-D

FP-68BXN/B-D

FP-85BXN/B-D

FP-102BXN/B-D

FP-34BXX/D-K(E)

FP-51BXX/D-K(E)

FP-68BXX/D-K (E)

FP-85BXX/D-K(E)

FP-34BXN/A-K (E)

FP-51BXN/A-K (E)

FP-51BWXN/A-K (E)

FP-85BXN/A-K (E)

FP-85BWXN/A-K (E)

(Note: "X" represent codes for A~Z, "N" represent codes for 1~N)

(E) Models applicable to EU

Thank you for choosing commercial air conditioners. Please read this Owner's Manual carefully before operation and retain it for future reference.

If you have lost the Owner's Manual, please contact the local agent or visit www.gree.com or send an email to global@cn.gree.com for the electronic version.

GREE ELECTRIC APPLIANCES, INC. OF ZHUHAI

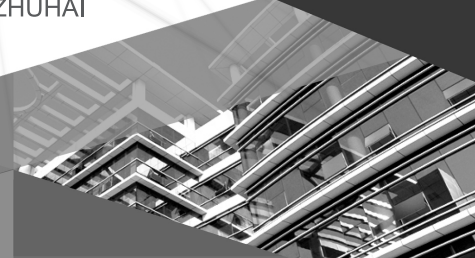

To Users

Thank you for selecting Gree's product. Please read this instruction manual carefully before installing and using the product, so as to master and correctly use the product. In order to guide you to correctly install and use our product and achieve expected operating effect, we hereby instruct as below:

- (1) This equipment should be installed, operated or maintained by the qualified servicemen who have had specific training. During operation, all safety issues covered in the labels, User's Manual and other literature should be followed strictly. This equipment is not intended for use by persons (including children) with reduced physical, sensory or mental capabilities, or lack of experience and knowledge, unless they have been given supervision or instruction concerning use of the appliance by a person responsible for their safety. Children should be supervised to ensure that they do not play with the appliance.
- (2) This product has gone through strict inspection and operational test before leaving the factory. In order to avoid damage due to improper disassembly and inspection, which may impact the normal operation of unit, please do not disassemble the unit by yourself. You can contact our designated dealer or local service center for professional support if necessary.
- (3) When the product is faulted and cannot be operated, please contact our designated dealer or local service center as soon as possible by providing the following information.
 - Contents of nameplate of product (model, cooling/heating capacity, product No., ex-factory date).
 - Malfunction status (specify the situations before and after the error occurs).
- (4) All the illustrations and information in the instruction manual are only for reference. In order to make the product better, we will continuously conduct improvement and innovation without further notice.

Contents

Safety Notices (Please be sure to abide)	1
1. Product Introduction	5
1.1 Working Principle.....	5
1.2 Main Parts	5
1.3 Working Conditions	6
2. Installation Instructions	7
2.1 Installation Dimension Diagram.....	7
2.2 Installation of the Rear Panel	7
2.3 Piping Holes for Installation.....	8
2.4 Installation of the Drain Pipe	8
2.5 Installation of the Connection Pipe.....	9
2.6 Installation of the Water Damper.....	10
2.7 Electric Wiring	10
3. Commissioning and Maintenance	11
3.1 Inspection after Installation.....	11
3.2 Trial Operation.....	11
3.3 Maintenance.....	12
4. Troubleshooting	14
4.1 Error List.....	14
4.2 Error Codes	16













Safety Notices (Please be sure to abide)











 **WARNING:** If not abide strictly, it may cause severe damage to the unit or the people.

 **NOTE:** If not abide strictly, it may cause slight or medium damage to the unit or the people.

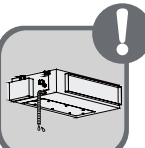







 This sign indicates that the operation must be prohibited. Improper operation may cause severe damage or death to people.

 This sign indicates that the items must be observed. Improper operation may cause damage to people or property.

⚠ WARNING			
	Please perform installation in accordance with this manual and read it carefully prior to startup and service.		Installation should be done by sales agents or qualified servicemen. Do not do it personally, as incorrect installation would lead to water leakage, electrocution, fire hazards etc.
	Before installation, check for power supply and see if it complies with that on the nameplate. Besides, check for safety of the power supply.		This unit should be grounded and there should be grounding lines for the power socket so as to prevent electrocution. Do not connect the grounding lines to the gas lines, water lines, lightning rod or telephone lines.
	Specialized components and parts should be used for installation; otherwise it would lead to water leakage, electrocution, fire hazards etc.		Size of the power lines should be large enough. Power lines and other electric connection lines should be replaced by specialized cables.
	When wiring of power lines is finished, remember to install a electric box to prevent safety accidents.		When installation is finished, check for connection of drain lines, water lines and electric lines, as incorrect connection would lead to water leakage, electrocution, fire hazards etc.
	Do not start or stop the unit by drawing out or plugging in the power plug.		Do not let the children play with this unit.
	Do not operate this unit with wet hands.		Do not clean this unit until the unit is turn off and the power supply is cut off, otherwise it would lead to electrocution or personal injury.

	<p>Do not spray or rinse this unit with water, as it would lead to malfunction or electrocution.</p>		<p>Do not let this unit exposed to moist, wet or corrosive environment.</p>
	<p>Volatile liquid like thinner or petroleum would damage appearance of this unit. (Only soft dry cloth and cloth with neutral detergent can be used to clean the outer casing of this unit.)</p>		<p>Do not make the set point too low under the cooling mode.</p>
	<p>Entering and leaving water lines, condensate lines and valves should be thermal insulated so as to prevent from dewing in summer.</p>		<p>Do not repair this unit by yourself, as incorrect repair would lead to electrocution or fire hazards. Please contact GREE after-sales center and repair should be done by the qualified servicemen.</p>
	<p>Never splice the power cord or use an extended cord. It can cause overheating or fire.</p>		<p>Don't insert your hands or stick into the air intake or outlet vents.</p>
	<p>Don't block the air intake of the FCU. It can decrease the FCU capacity or cause a malfunction.</p>		<p>Keep combustilbe spray away from the units more than 1.5m. It can cause a fire or explosion.</p>

△NOTE

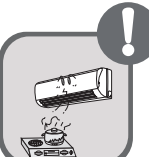
	<p>During operation, do not insert fingers or other objects into the moving parts, which would lead to unnecessary injuries.</p>		<p>Please cut off the power supply when this unit is not used for long time in consideration of safety.</p>
	<p>When there is something unusual (like unusual smell, burning smell, smoke etc.), please turn off the unit and cut off the main power supply at once, and then contact GREE after-sales servicemen. If unusual conditions go on, this unit would burn out, or even it would lead to electrocution or fire hazards.</p>		<p>Wiring of power lines and electric connection lines should be secure enough. Terminals also should be tightly fastened. The connection line should not suffer external forces. For the unit equipped with the wired controller, the controller would be powered on firstly; otherwise it would be out of normal use.</p>
	<p>The filter should be cleaned periodically in case that heat exchanging effect would be affected.</p>		<p>Please do freeze protection in winter to prevent copper tubes from cracking.</p>
	<p>Don't leave windows and doors open for a long time while operating the FCU. It can decrease the FCU capacity.</p>		<p>Don't blow the wind to animals and plants directly. It can cause a bad influence to them.</p>
	<p>Don't use the FCU for other purposes, such as drying clothes, preserving foods, etc.</p>		<p>Don't place a space heater near the FCU.</p>

This appliance is intended to be used by expert or trained users in shops, in light industry and on farms, or for commercial or household use by lay persons.

Installing the unit in the following places may cause malfunction. If it is unavoidable, please consult the local dealer:

- (1) The place with strong heat sources, vapors, flammable or explosive gas, or volatile objects spread in the air.
- (2) The place with high-frequency devices (such as welding machine, medical equipment).
- (3) The place near coast area.
- (4) The place with oil or fumes in the air.
- (5) The place with sulfureted gas.
- (6) Other places with special circumstances.
- (7) Do not use the unit in the immediate surroundings of a laundry, a bath, a shower or a swimming pool.

DISPOSAL: This marking indicates that this product should not be disposed with other household wastes throughout the EU. To prevent possible harm to the environment or human health from uncontrolled waste disposal, recycle it responsibly to promote the sustainable reuse of material resources. To return your used device, please use the return and collection systems or contact the retailer where the product was purchased. They can take this product for environmental safe recycling.



This appliance can be used by children aged from 8 years and above and persons with reduced physical, sensory or mental capabilities or lack of experience and knowledge if they have been given supervision or instruction concerning use of the appliance in a safe way and understand the hazards involved. Children shall not play with the appliance. Cleaning and user maintenance shall not be made by children without supervision.

1. Product Introduction

1.1 Working Principle

The cold (hot) water entering the heat exchanger will do heat exchanging with air passing through the surface of the heat exchanger to condition the air temperature and humidity. There is no (cold) hot source for this product itself. The running mode depends on the environment temperature and the running mode of the main unit.

Protection against hot air

Under the cooling mode, when the water temperature is too high, the fan will be stopped to avoid the unit from blowing out hot air.

Protection against cold air

Under the heating mode, when the water temperature is too low, the fan will be stopped to avoid the unit from blowing out cold air.

Memory function

Upon power failure, some statuses can be memorized, including: mode setting, fan speed setting, fan swing setting, temperature setting etc.

1.2 Main Parts

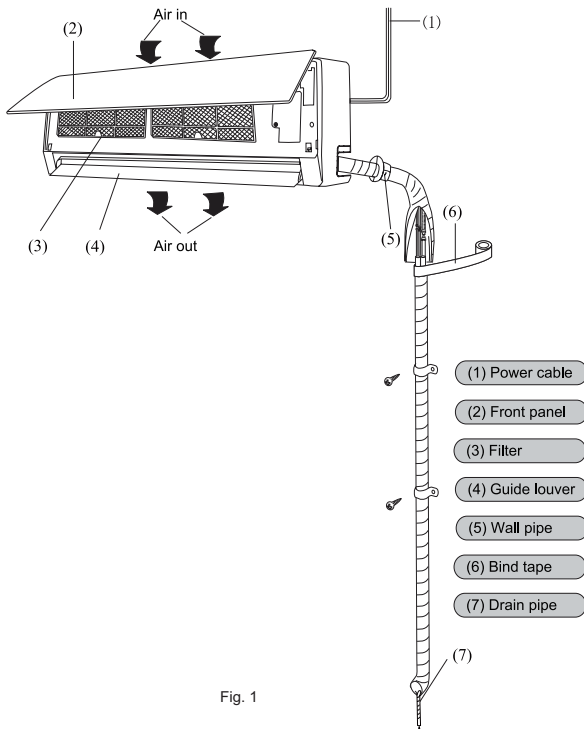

Fig. 1

1.3 Working Conditions

- (1) The entering water temperature for cooling is suggested to be no less than 5°C ,otherwise it would lead to condensate; the entering water temperature for heating is suggested to be not higher than 60 °C , otherwise it would lead to corrosion of copper tubes or abnormal noise.
- (2) The suggested working environment temperature for cooling ranges 16 ~ 40°C and ranges 10 ~ 35°C for heating. Beside, the relative humidity is or less than 80%.
- (3) This product is a kind of comfort air conditioning, and is not allowed to be installed where there are corrosive, explosive and inflammable substances or smog; otherwise it would lead to operation failure, shortened service life, fire hazard or even severe injuries. Special air conditions are required for where mentioned above.
- (4) The A-weighted sound pressure level is below 70dB.
- (5) The temperature exchange efficiency and enthalpy exchange efficiency are tested under these testing conditions as below:
 - Cooling capacity: air 27°C DB , 19°C WB, water temperature intake 7°C, outlet 12°C.
 - Heating capacity: air 20°C DB , For the tow-row coils applicable to EU, the entering/leaving water temperature is 45°C and 40°C; and for the four-row coils, the entering/leaving water temperature is 65°C/55°C.
 - Freeze-up : air 27°C DB, 24°C WB , water temperature 6°C intake , 10°C outlet .
 - Sound power level according to ISO 5151. Sound pressure level are calculated at the below of air-outlet 1m and 1m distance. The noise are tested before leaving factory.

2. Installation Instructions

2.1 Installation Dimension Diagram

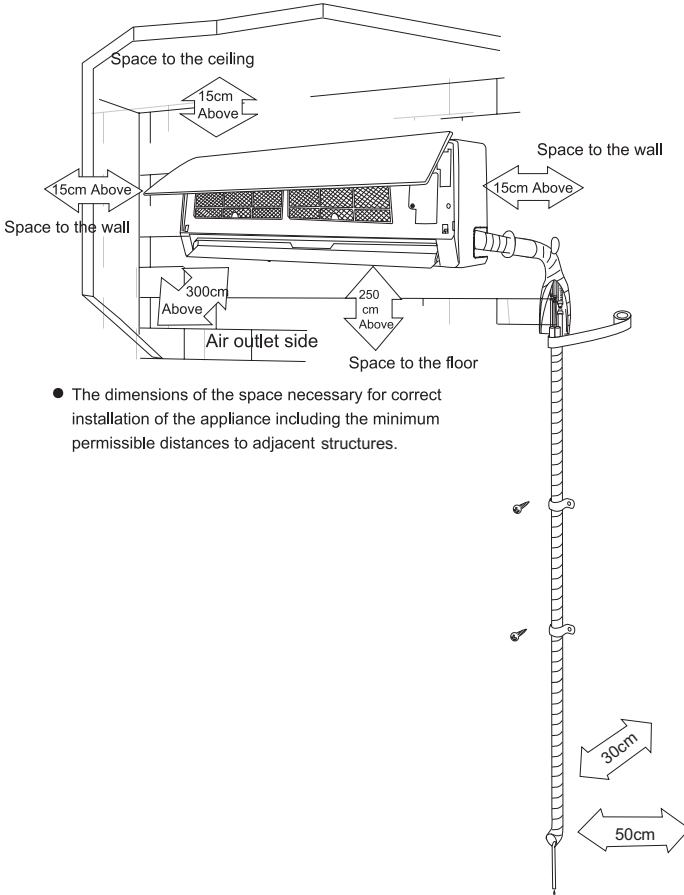

Fig.2

2.2 Installation of the Rear Panel

- (1) Always mount the rear panel horizontally. Due to the water tray of the unit has been adopted the both-way drainage design, the outlet of water tray should be adjusted slightly down when installing, that is to take the outlet of the water tray as the center of a circle, the included angle between the evaporator and level should be 0 or more, that is good for condensing water drainage.

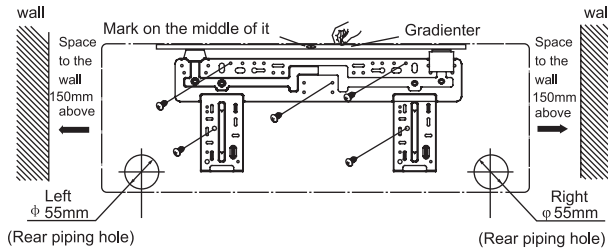

Fig. 3

- (2) Fix the rear panel on the wall with screws. (Where is pre-covered with plastic granula)
- (3) Be sure that the rear panel has been fixed firmly enough to withstand the weight of an adult of 60kg, further more, the weight should be evenly shared by each screw.

2.3 Piping Holes for Installation

- (1) Make the piping hole ($\Phi 55$) in the wall at a slight downward slant to the outdoor side.
- (2) Insert the piping-hole sleeve into the hole to prevent the connection piping from being damaged when passing through the hole.

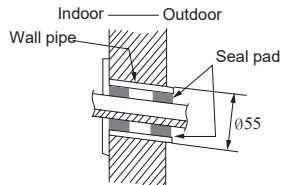

Fig. 4

2.4 Installation of the Drain Pipe

- (1) For smooth draining, the drain hose should be placed at a downward slant.
- (2) Do not wrench or bend the drain hose or flood its end by water.
- (3) When the long drainage hose passing through indoor, should wrap the insulation materials.

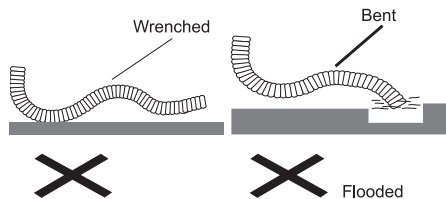
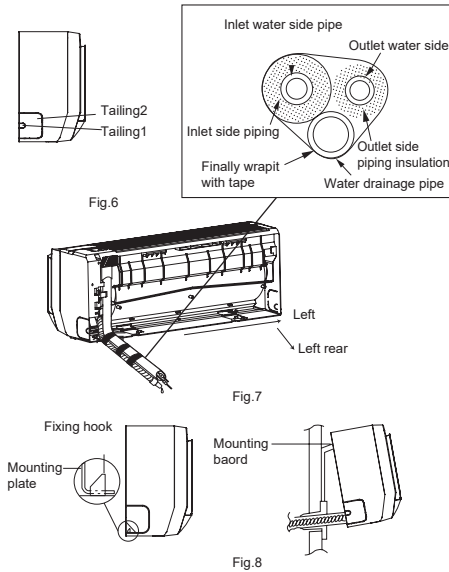

Fig. 5

2.4.1 The piping can be lead out from left, left rear.

- (1) When routing the piping and wiring from the left side of the unit, cut off the tailings from the chassis in necessary (Show in Fig.6)
 - Cut off the tailings 1 when routing the wiring only;
 - Cut off the tailings 1 and tailings 2 when routing both the wiring and piping.
- (2) Take out the piping from body case, wrap the piping electric wire, water pipe with tape and pull them through the piping hole (As show in Fig.7)
- (3) Hange the mounting slots of the FCU on the upper tabs of the rear panel and check if it is firm enough.

(As show in Fig.8)



2.5 Installation of the Connection Pipe

- (1) Align the center of the piping pipe with the relevant valve.
- (2) Place the nut, spring washer, washer, O-ring cross the pipe sequentially, and keep them tightly close to each other with a distance of 6-7mm from the O-ring to the pipe end.
- (3) Screw in the pipe nut by hand and then tighten the nut with spanner.
- (4) If supplied by the manufacturer, the connection pipe shall be installed in place so as to guarantee the reliable connection.

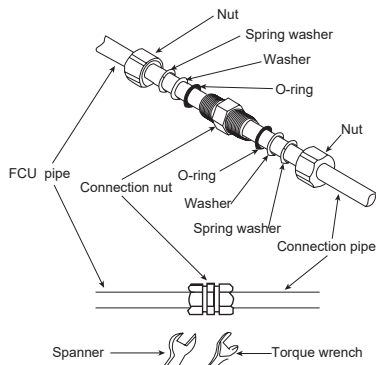

Fig. 9

NOTE

- Firstly connect the connection pipe to the FCU pipe, then to the connection pipe; pay attention to the piping bending, do not damage the connection pipe; the joint nut couldn't tighten too much, otherwise it may cause leakage.

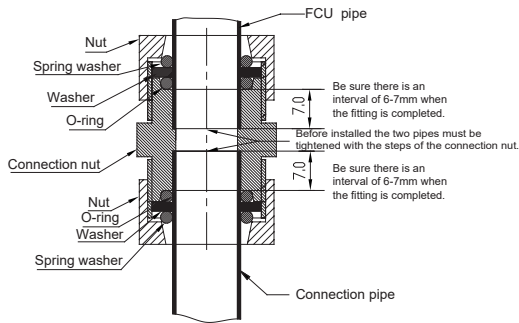

Fig. 10

2.6 Installation of the Water Damper

All units must be equipped with a motorized valve because of the following main reasons.

- (1) There would be a water flood risk for some units without motorized valves in the event that they stop under the cooling conditions.
- (2) Under the cooling and heating conditions, energy loss would happen to the chilled water and hot water.

Notes:

- (a) The pipe must be wrapped by heat insulation material to prevent condensing water drips.
- (b) It is prohibited to bind directly the water valve wire and sponge up with the copper tube, as there would be probably a short circuit or even electric leakage. The right way is letting the water valve wire go through the pipe sleeve and then binding the sponge and pipe sleeve.
- (c) It is prohibited to put the valve core upside down.

2.7 Electric Wiring

2.7.1 Safety Precautions for Electric Appliances

- (1) A dedicated power supply circuit should be used in accordance with local electrical safety regulations.
- (2) Don't drag the power cord with excessive force.
- (3) The unit should be reliably earthed and connected to an exclusive earth device by the professionals.
- (4) The air switch must have the functions of magnetic tripping and heat tripping to prevent short circuit and overload.
- (5) The minimum distance between the unit and combustive surface is 1.5m.
- (6) The appliance shall be installed in accordance with national wiring regulations.
- (7) An all-pole disconnection switch with a contact separation of at least 3mm in all poles should be connected in fixed wiring.

NOTE

- Make sure the live wire, neutral wire and earth wire in the family power socket are properly connected. There should be reliable circuit in the diagram.
- Inadequate or incorrect electrical connections may cause electric shock or fire.

2.7.2 Earthing Requirements

- (1) The FCU is type I electric appliance. Please ensure that the unit is reliably earthed.
- (2) The yellow-green wire in air conditioner is the earthing wire which can not be used for other purposes. Improper earthing may cause electric shock.
- (3) The earth resistance should accord to the national criterion.

(4) The power must have reliable earthing terminal. Please do not connect the earthing wire with the following:

① Water pipe ② Gas pipe ③ Contamination pipe ④ Other place that professional personnel consider is unreliable

(5) The model and rated values of fuses should accord with the silk print on fuse cover or related PCB.

2.7.3 Connection of the electric wire

When connecting the electric wire if the wire length is not enough, please contact with the authorized service shop to buy a exclusive electric wire that is long enough and the joint on the wire are not allowed.

- (1) The electric wiring must be correctly connected, wrong connection may cause spare parts malfunction.
- (2) Tighten the terminal screw in order to prevent loose.
- (3) After tighten the screw, slight pull the wire and confirm whether is it firm or not.
- (4) If the earth wire is wrong connection, that may cause electric shock.
- (5) The cover plate must be fixed, and tighten the connection wire, if it is poor installed, that the dust, moisture may enter in or the connection terminal will be affected by outside force, and will cause fire or electric shock.

3. Commissioning and Maintenance

3.1 Inspection after Installation

Items to be checked	Possible malfunction
Has it been fixed firmly?	The unit may drop, shake or emit noise.
Have you done the water leakage test?	It may cause insufficient cooling (heating) capacity.
Is heat insulation sufficient?	It may cause condensation and dripping.
Is water drainage well?	It may cause condensation and dripping.
Is the voltage in accordance with the rated voltage marked on the nameplate?	It may cause electric malfunction or damage the part.
Is the electric wiring and piping connection installed correctly and securely?	It may cause electric malfunction or damage the part.
Has the unit been connected to a secure earth connection?	It may cause electrical leakage.
Is the power cord specified?	It may cause electric malfunction or damage the part.
Is the inlet and outlet been covered?	It may cause insufficient cooling(heating)capacity.

3.2 Trial Operation

3.2.1 Before Trial Operation

- (1) Do not switch on power before installation is finished completely.
- (2) Electric wiring must be connected correctly and securely.
- (3) All the impurities such as scraps and thums must be cleared from the unit.

3.2.2 Trial Operation Steps

- (1) Switch on power, pressing "ON/OFF" button on the wireless remote control to start the test mode.
- (2) Press TURBO button no less than 3 times during 5 seconds. The FCU run at test mode.

- (3) Using the controller, the FCU can select the COOL, HEAT, FAN, DRY to check whether the operation is normal or not.
- (4) Leave test mode to pressing "ON/OFF" button on the controller.
- (5) During 5 minute, the FCU would leave test mode automatically without pressing any button.
- (6) Switch off the FCU, pressing "ON/OFF" button on the controller.

3.3 Maintenance

3.3.1 Emergency Operation

When the wireless remote control is lost or damaged, please use the AUTO button. At this time, sketch map for changing batteries cassette type fan coil unit 9 the unit will operated as follow:

- (1) At operation: When the unit stop , pressed AUTO button over 5 seconds, the unit run.
- (2) At stopping: When the unit is running, pressed AUTO button and overrun 5 seconds, the unit stop.
- (3) When the unit is running, pressed AUTO button less than 5 seconds. The unit select from COOL, DRY, FAN, HEAT, COOL modes automatically.

Open the front panel, the manual switch is on the edge as Fig.11.

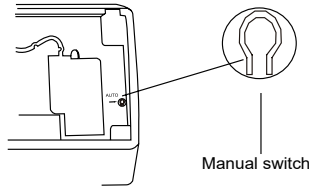

Fig.11

3.3.2 Care and Cleaning

NOTE

- Turn power off and pull out the power plug before cleaning air conditioner, or it may cause electric shock.
- Never sprinkle water on the unit for cleaning because it can cause an electric shock.
- Volatile liquid (e.g. thinner or gasoline) will damage the air conditioner. (So wipe the units with a dry soft cloth, or a cloth slightly moistened with water or cleanser.)

(1) Cleaning the front panel

When cleaning the front panel, please dip the cloth into the water temperature of 45℃ below, then to dry the cloth and wipe the dirty part.

(2) Cleaning the air filter (Recommended once every three months)

NOTE

- If dust is much more around the air conditioner, the air filters should be cleaned many times. After taking off the filter, don't touch the fin of the unit, in order to avoid hurt your fingers.

- Take down the air filter

At the slot of surface panel to open an angle, pull the air filter downward and take it out, please see the Fig. 12(a, b).

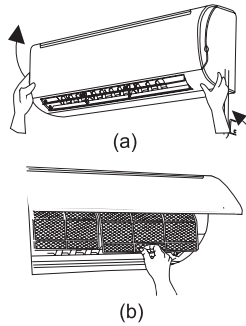

Fig.12

- Clean the air filter

To clean the dust adhering to the filters, you can either use a vacuum cleaner, or wash them with warm water the water with the neutral detergent (below 45°C), and dry it in the shade.

NOTE

- Never use water above 45°C to clean, or it can cause deformation or discoloration. Never parch it by fire, or can cause a fire or deformation.

- Reinstall the air filter

Reinsert the filters along the direction of arrowhead, and then to cover the cover and clasp it.

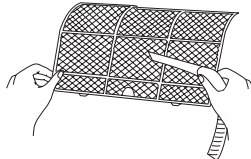

Fig.13

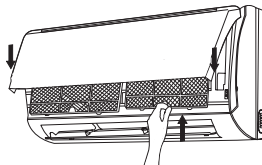

Fig.14

3.3.3 Installation and Maintenance of Healthy Filter (optional)

- ◆ Installation Instructions

- (1) Forcibly pull the panel for a specific angle from the two ends of the front panel according to the arrow direction. Then pull the air filter downwards to remove it. (See Fig.15)
- (2) Mount the healthy filter onto the air filter,(as shown in Fig.16). If the air filter cannot be installed,please mount the healthy filter on the front case. (as shown in Fig.17)
- (3) Mount the air filter properly along the arrow direction in Fig.18, and then close the panel cover.

- ◆ Cleaning and Maintenance.

Take out the healthy filter before cleaning and reinstall it after cleaning according to the installation instruction. Pay special attention that silver ion filter can't be cleaned with water, while active carbon,

photocatalyst, low temperature conversion (LTC) catalyst, formaldehyde eliminator, catechin or mite killing filter can, but can't with brush or hard things. Dry it in the shade or sun after cleaning, but not by wiping.

◆ Service Life

- (1) The healthy filter commonly has its usage lifetime for one year under normal condition. As for silver ion filter, it is invalid when its surface becomes black (green).
- (2) This supplementary instruction is provided for reference to the unit with healthy filter. If the graphics provided herein is different from the physical goods, the latter one shall prevail. The quantity of healthy filters shall be based on the actual delivery.

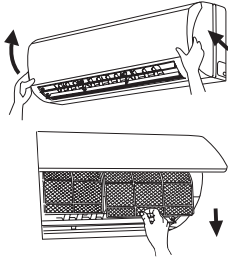

Fig.15

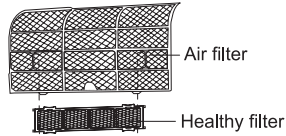

Fig.16

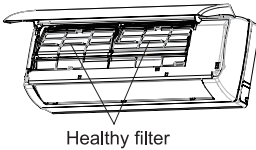

Fig.17

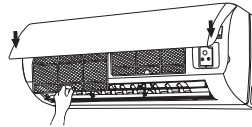



Fig.18



4. Troubleshooting

4.1 Error List

⚠ CAUTION

- The FCU is not expected to be serviced by users. Incorrect repair may cause electric shock or fire, so please contact an authorized service center for professional service. The following checks prior to contact may save your time and money.

Phenomenon	Troubleshooting
<p>The unit does not operate:</p> 	<ul style="list-style-type: none"> • Blow of fuse or breaker • Power cut • Don't connect with power • Low batteries of wireless remote controller • Wireless remote controller exceed remote control area

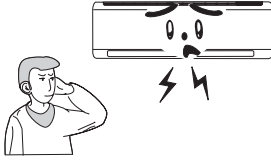
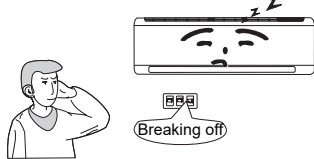
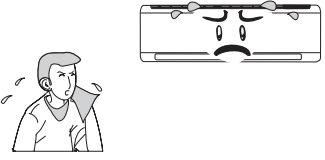
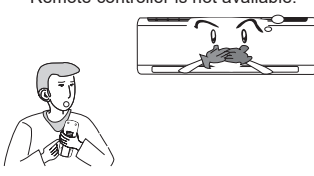
<p>Odours are emitted:</p> 	<ul style="list-style-type: none"> • Some odours may be emitted from the FCU. This is the result of room smells (such as furniture, tobacco, ect.) which have been taken into the FCU. • Consult authorized service center for cleaning if the odours still exist.
<p>Mist is emitted in COOL mode</p> 	<ul style="list-style-type: none"> • During cooling operation, a thin mist may be seen emitted from the FCU due to high room temperature and humidity. After a period of time, the mist will disappear with the decrease of room temperature and humidity.
<p>Cracking noise:</p> 	<ul style="list-style-type: none"> • This is the sound of friction caused by expansion and/ or contraction of panel or other parts due to the change of temperature.
<p>The unit can not be started up:</p> 	<ul style="list-style-type: none"> • Is the power cut off? • Is the power plug loose? (If applicable) • Is the circuit protection device tripped off? • Is voltage higher or lower?(Tested by professionals) • Is the TIMER correctly used?
<p>Cooling/Heating effect is poor:</p> 	<ul style="list-style-type: none"> • Is temperature setting appropriate? • Is the inlet or outlet blocked? • Is the filter dirty? • Is the window or the door open? • Is low fan speed set? • Are there heat sources in the room?
<p>Remote controller is not available:</p> 	<ul style="list-style-type: none"> • Check if there is magnetic or electrical interference near the unit that may affecting operation of the controller. In this case, pull the plug out and reinsert it. • Is the remote controller within its operating range or obstructed? Check the condition of the batteries and replace them if necessary. • Check if the remote controller is damaged.
<p>Water leakage of FCU.</p>	<ul style="list-style-type: none"> • The humidity is high. • Condensate overflows. • Drain hose is loose.

Noise from FCU.	<ul style="list-style-type: none"> The noise emitted when the fan is switching on or off.
FCU can not blow air:	<ul style="list-style-type: none"> In HEAT mode, when the temperature of FCU heat exchanger is very low, air flow is stopped in order to prevent cold air. In COOL mode, when the temperature of FCU heat exchanger is very high, air flow is stopped in order to prevent hot air.
Moisture on air outlet :	<ul style="list-style-type: none"> If the unit operates at high humidity for a long time, moisture will be generated on the air outlet grill and then drip off.
C5:Malfunction of connector jumper:	<ul style="list-style-type: none"> Check if the connector jumper contacts properly. If the PCB is to be replaced, please take off the old for the new PCB.
F0:Malfunction of the ambient temperature sensor	<ul style="list-style-type: none"> Check if the room temperature sensor is connected properly
F1:Malfunction of evaporator temperature sensor	<ul style="list-style-type: none"> Check if the evaporator temperature is connected properly.
 If any one of the following situations occurs, immediately stop all operations, cut off the power supply, and contact the authorized personnel.	

- There is harsh sound during operation.
- Strong odours are emitted during operation.
- Water is leaking from the unit.
- The air switch or protection switch often trips.
- Water or other liquid is splashed into the unit.
- Power cord and power plug is overheating.



Stop operation and cut off the power supply.

4.2 Error Codes

Error Codes	Error Description
F0	Indoor unit main board environment temperature sensor error
F1	Cooler pipe temperature sensor error
F5	Control panel ambient temperature sensor error
H6	PG motor stalling protection
C5	Jumper error
E6	Communication error

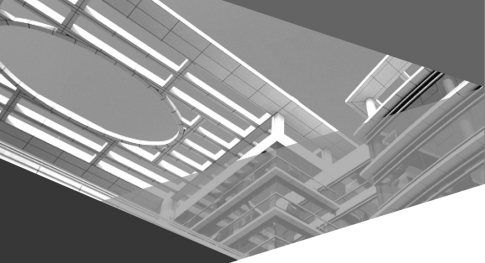

GREE ELECTRIC APPLIANCES, INC. OF ZHUHAI

Add: West Jinji Rd, Qianshan, Zhuhai, Guangdong, China, 519070

Tel: (+86-756) 8522218

Fax: (+86-756) 8669426

E-mail: global@cn.gree.com www.gree.com



600005060408